

L
L2
L3
SL
S
D
d
W
R / W2
L4 max

- Innenkühlung
Internal cooling
- Rechtslauf
right rotation
- Linkslauf
left rotation
- DP-bestückt
DP-tipped
- Diamant beschichtet
diamond coated
- Antihaft beschichtet
non stick coated
- VHW (Hartmetall)
solid carbide

Maschinendaten
machine data

n max (Drehzahl max) _____ 1/min
 n max (rpm max)

vf max (Vorschub) _____ mm/min
 vf max (feed rate)

Vorschub manuell mechanisch
 feed rate manual mechanical

Spannmittel (Schnittstelle + Schaftspannung) _____
 Clamping devices (interface and shaft clamping)

Werkstückstoff
workpiece

Schicht 1 stack 1	_____ mm	Stoffart 1 fabric type 1	<input type="checkbox"/> Sackloch blind hole <input type="checkbox"/> Durchgangsloch through hole
Schicht 2 stack 2	_____ mm	Stoffart 2 fabric type 2	
Schicht 3 stack 3	_____ mm	Stoffart 3 fabric type 3	
Bohrtiefe drilling depth		_____ mm	
Toleranz Bohrung tolerance hole		_____ mm	+ _____ - _____

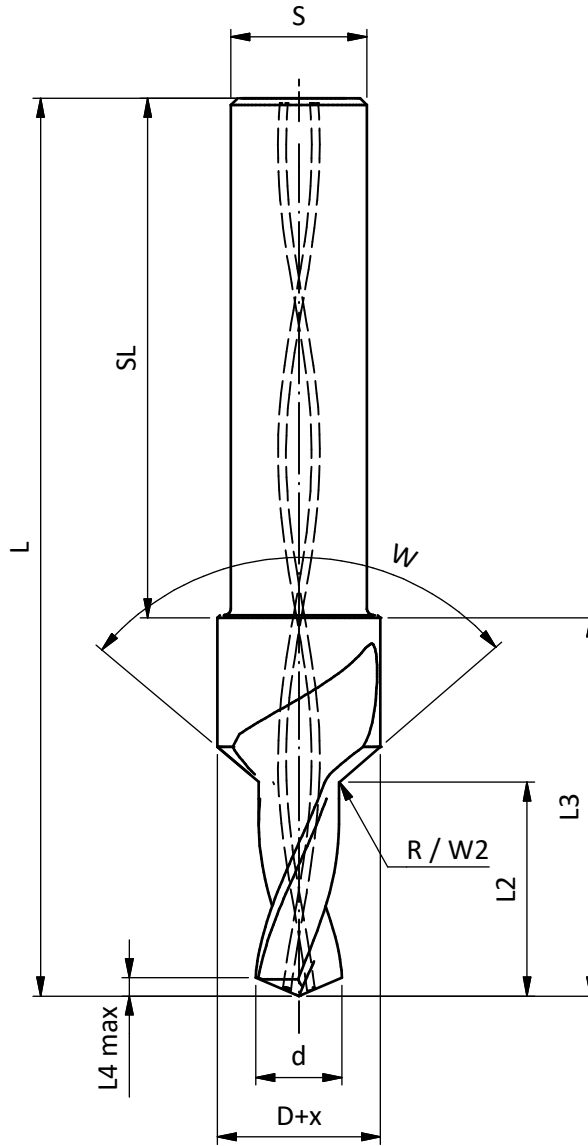

Kundenangaben customer information
Projektnummer projekt number
Datum date
Notizen note
Angefragte Stückzahl quantity of pieces
Jahresbedarf / Losgröße pro Abruf Annual demand / Lot size per call-off
Aktuelle Bearbeitung actual process

